

## GYPSUM BOARD OR PLASTER WALLS

With metal or wood studding, install a framed opening at specified location. Opening dimensions should be  $3/8$ " larger than the frame I.D. of the panel; i.e., for a 12" x 12" panel, opening should be 12- $3/8$ " x 12- $3/8$ ".

2. Frame all four sides of the access panel.
3. On panels larger than 16" x 16", install a double stud on both sides in the same manner as at passage panels.
4. Place panel in position in opening and mark location of attachment on studding using holes in all four sides of panel frame as marking guide.
5. Remove panel and drill  $5/32$ " holes through studs at marked points. Four attachment holes for panels 32" x 32" and smaller; six attachment holes for larger panels.
6. Place panel in position and attach with #10 sheet metal or machine screws.
7. Check panel for freedom of movement. If it binds, shim as necessary to remove any racking of frame at attachment to studding.

Use proper sealant around the screws and behind the flange to provide adequate closure between wall and panel.

## MASONRY WALLS

1. Opening should be planned to dimensions  $3/8$ " larger than door size of panel; i.e., for a 12" x 12" panel, opening should be 12- $3/8$ " x 12- $3/8$ ".
2. Position the panel in the wall opening provided for it and mark location of attachments on wall using holes in latch and hinge sides of panel frame as marking guides.
3. Remove panel and install expansion shields in wall at marked points. Install four for panels 32" x 32" or smaller, six for larger panels.
4. Place panel in position and attach with #10-32 x 1" long flat head steel machine screws or equivalent.
5. Check panel for freedom of movement. If it binds, shim as necessary to remove any racking of frame at attachments to masonry.
6. Use mortar to frame of panel and block wall to provide a complete closure around frame of panel. Use adequate sealant around the screws.

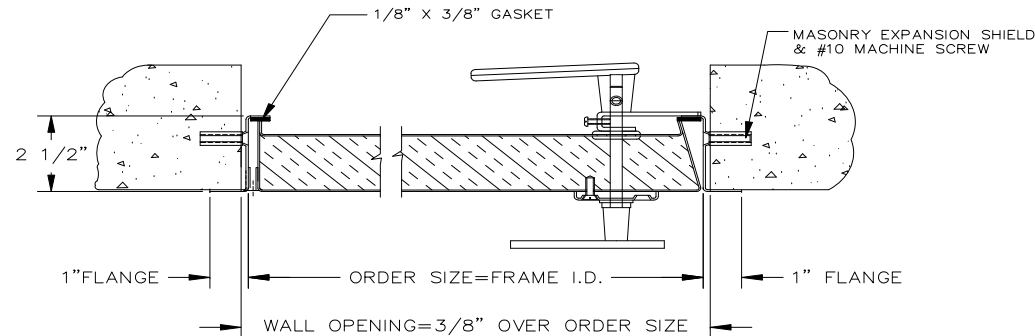

JL INDUSTRIES

**ACTIVAR**  
INC.

Construction Products Group

A DIVISION OF

[www.activarcpg.com](http://www.activarcpg.com)

## XPA EXTERIOR ACCESS DOORS WALL INSTALLATION INSTRUCTIONS

HEADQUARTERS - JL INDUSTRIES :4450 WEST 78<sup>TH</sup> ST CIRCLE, BLOOMINGTON, MN 55435-5416 PH: 800-554-6077 FAX: 952-835-2218 EMAIL: [JL@JLINDUSTRIES.COM](mailto:JL@JLINDUSTRIES.COM) [WWW.ACTIVARCPG.COM](http://WWW.ACTIVARCPG.COM)  
ACPG WEST COAST -SAMSON PRODUCTS: COMMERCE, CA PH: 323-726-9070 FAX: 323-726-9068 • ACPG SOUTHEAST -THOMAS ENTERPRISES: FT MEYERS, FL PH: 239-693-7500 FAX: 239-693-7501